

REVISIONS				
ZONE	REV	DESCRIPTION	DATE	APPROVED
--	1	INITIAL RELEASE	02012-JUN-04	--
	2	ADDED COLOR SHEET 2	02013-NOV-11	
	3	REPLACED PINCH W/ SPLIT CLAMP	02015-JUN-09	

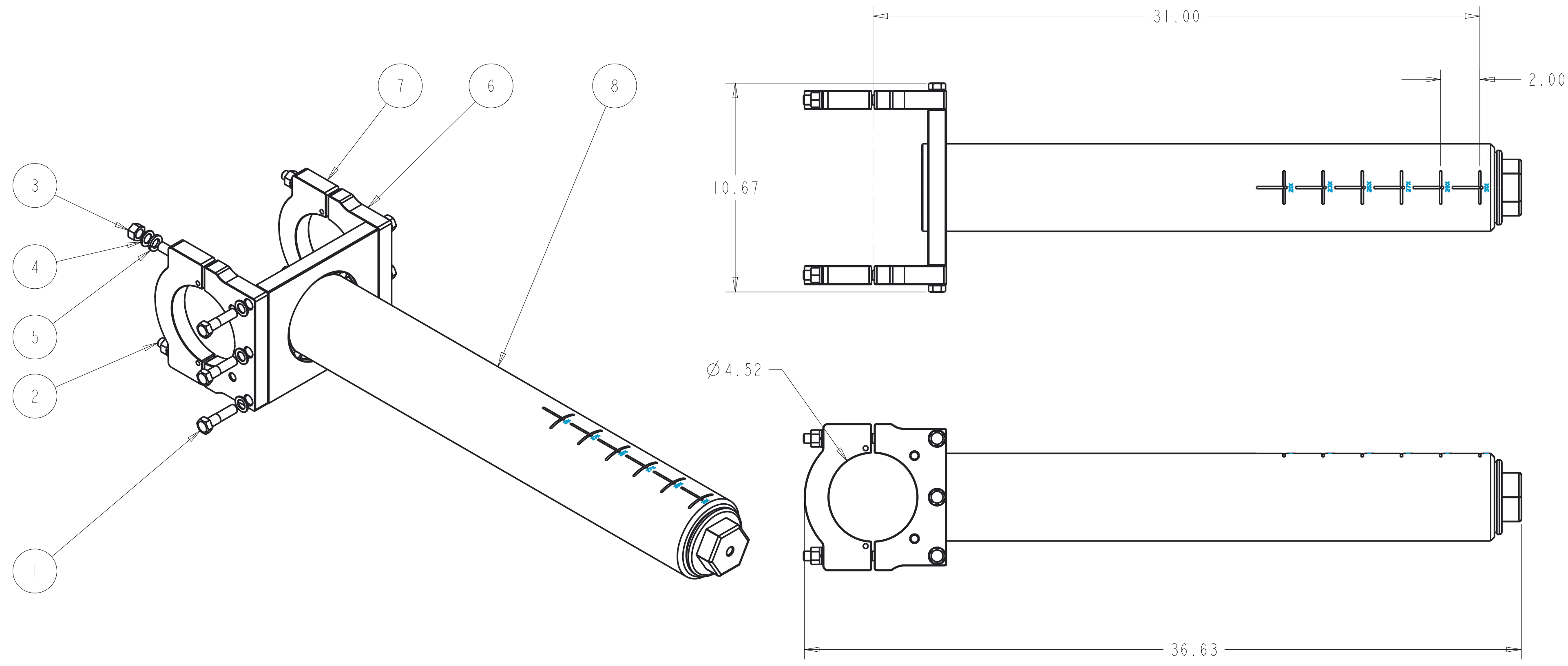

ITEM NO.	QTY RECD.	PART NO.	DRAWING TITLE OR DESCRIPTION	MANUFACTURER	MFG PART NO.
8	1	500-9433-02	USM, X-POLE WELDMENT, 31" BUILD LENGTH	ASSY	---
7	2	500-1435-02	USM, Z CLAMP, SPLIT TOP CLAMP	FAB	---
6	2	500-1435-01	USM, Z CLAMP, SPLIT BASE	FAB	---
5	4	90-310-510-870-120-20	WASHER, SPLIT LOCK .510 ID X .87 OD X .120TK, 18-8 SST	MCMASTER	92146A033
4	10	90-300-515-875-060-20	WASHER, .515 ID X .875 OD X .060 18-8	MCMASTER	98017A210
3	4	90-200-500C-20	NUT, 1/2-13 UNC, 18-8	MCMASTER	91845A310
2	4	90-140-500C-5000-1500-20	STUD, 1/2-13, 5" OAL, 1.5 THREAD, 18-8	MCMASTER	98962A535
1	6	90-104-500C-2000-20	HEX BOLT, 1/2-13 X 2.000 SST 18-8	MCMASTER	92198A720

TOLERANCES ARE:	PRO/E REPORTED PARAMETERS		DESIGNER	
	PRO/E MATERIAL	PRO/E MASS	ENGINEER	G STAPLES
.X +/- 0.1	N/A	30.546	GS	02012-JUN-04
.XX +/- 0.01			DRAFTER	G STAPLES 02012-JUN-04
.XXX +/- 0.001			CHECKED	---
ANGLES +/- 0.5				02012-JUN-04
INTERPRET DIMENSIONS PER ASME Y14.5M 1994 (R2004)	PRO/E DRAWING FILE NAME: 500-9430-02		DO NOT SCALE DRAWING	

UNIVERSAL SONAR MOUNT		
USM, X-POLE W/CLAMP SUB ASSY, 31"		
SIZE	CUSTOMER DRAWING/PART NO.	REV
C	---	3
DRAWING/PART NO. 500-9430-02		
SCALE	0.250	SHEET 1 OF 2

CUSTOMER DRAWING/PART NO. ---
 DRAWING/PART NO. 500-9430-02
 REV 3
 SH 1

4

3

2

1

REVISIONS
SEE SHEET 1

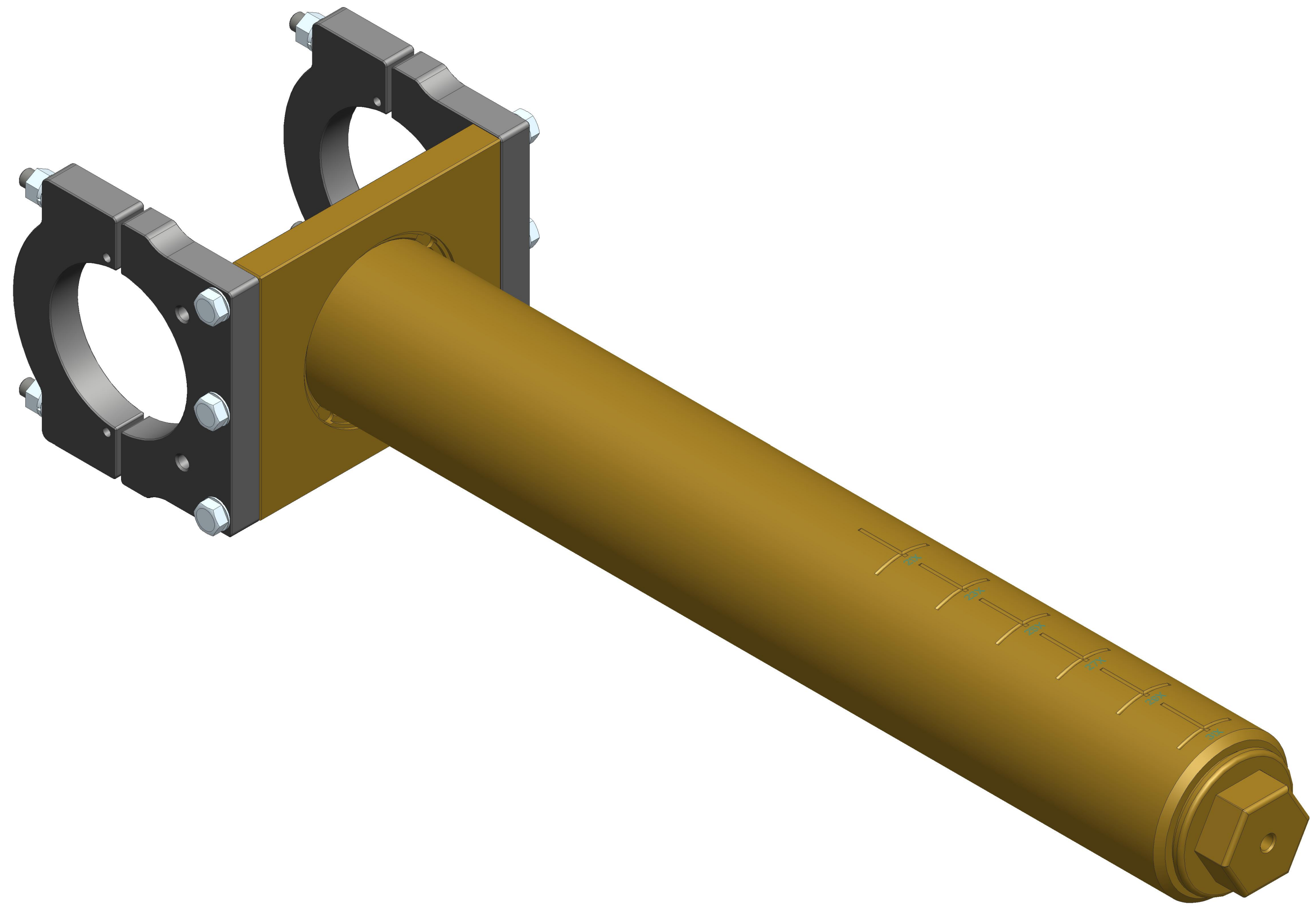

D

D

C

CUSTOMER DRAWING/PART NO. ---

B

DRAWING/PART NO. 500-9430-02

A

REV 3
SHT 2

UNIVERSAL SONAR MOUNT		
USM, X-POLE W/CLAMP SUB ASSY, 31"		
SIZE	CUSTOMER DRAWING/PART NO. ---	REV
C	DRAWING/PART NO. 500-9430-02	3
SCALE	0.500	SHEET 2 OF 2

4

3

2

1

A